

UNIDROP 
PATENTED TECHNOLOGY ®



INSTALLATION GUIDE

—
**AREA
FLOORS**

New Generation Flooring
www.areafloos.com.tr

INSALLATION INSTRUCTIONS

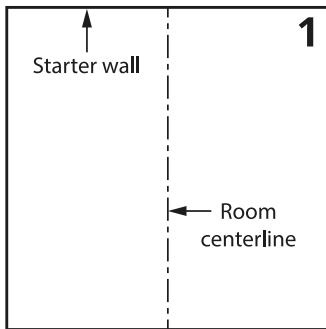

Step 1. Measure the room before you start fitting. Indicate the middle of the width of the room, as shown in figure 1.

Step 2. Make sure that you have an equal amount of A & B types of panels. Later in these instructions the A type panels will be indicated with the letter A, the B type panels will be indicated with letter B.

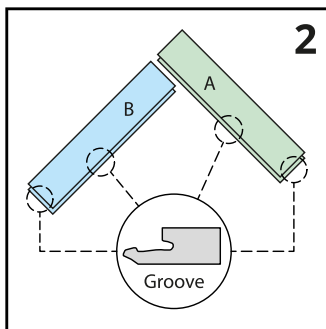

Tip: During installation, make sure that you mix up the A & B types of panels sufficiently so that there are not too many identical, lighter or darker panels next to each other. Fit an underlay if necessary.

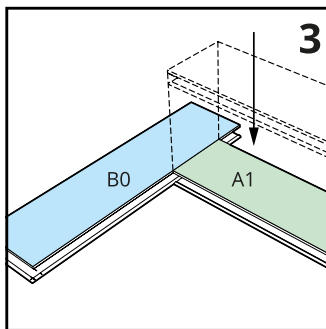

Step 3. Start by positioning the panels in the correct orientation before you install them. Panels (A) and (B) should be positioned with the tongue side facing the starter wall, meaning that the long side groove of both panels (A) and (B) are facing towards you. Panel (B) should be positioned with the tongue on the short side towards panel (A). See figure 2.

Step 4. Position an extra panel (B0) above panel (A1). The purpose of panel (B0) is to ensure correct alignment of the following panels. It will be removed later.

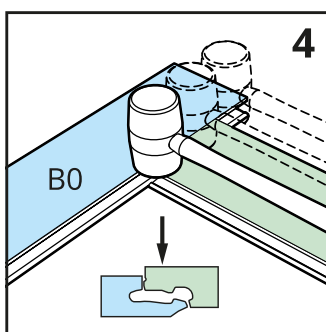

Connect the tongue of the short side of panel (A1) with the groove of the long side of panel (B0) with a drop-down movement, as shown in figure 3. Use a rubber hammer to fully connect the short side of panel (A1). The hammering should be done in the direction of and partly over panel (B0). Please be careful not to damage the profile or edges while engaging the panels. See figures 4 and 5.

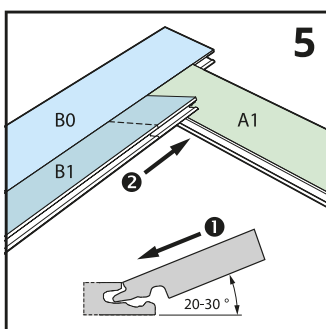

Step 5. The long sides of the panels must be joined by an "angle movement". Insert the tongue of panel (B1) into the

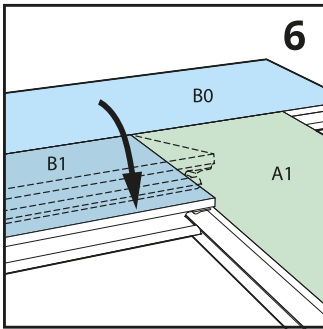

groove of panel (B0) at an angle of about 20-30 degrees. Slide panel (B1) until the tongue on the short side is positioned just above the groove of panel (A1), then press panel (B1) down to ensure the long sides of panels (B1) and (B0) are connected. Finally connect the tongue on the short side of panel (B1) by making use of the rubber hammer, in the same way as described above. See figures 6-8.

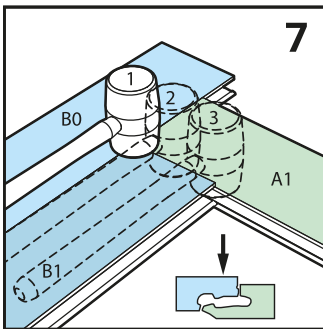

Make sure that the joints are completely engaged over the whole length of the panel. If the angle movement doesn't go easily, it means that the planks aren't correctly engaged with each other.

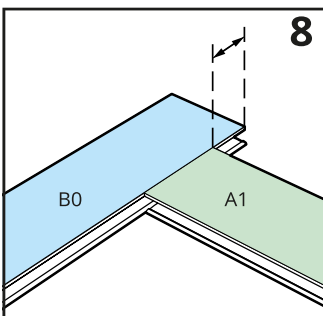

Step 6. The next step is to connect another (B) panel with the already installed panel (A1) at an "angle movement". Insert the tongue of this panel (B1-2) into the groove of panel (A1) at an angle of about 20-30 degrees and press panel (B1-2) down. See figure 9. Make sure that the edges of the two panels are perfectly aligned with each other.

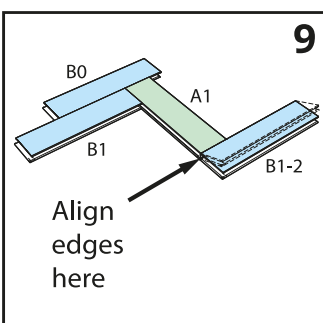

Step 7. Now you can install plank (A2) in the same way as you installed panel (B1). Connect the tongue of the long side of panel (A2) with the groove of the long side of panel (A1) at an angle of about 20-30 degrees. When the long sides are correctly installed, you can connect the tongue of the short side of panel (A2) with a fold-down movement into the groove of the long side of panel (B1). Fully engage these short sides by making use of the rubber hammer, in the same way as described above. See figures 10 - 13. Install the next (B) panel in the first V-row of your floor in the same way. See

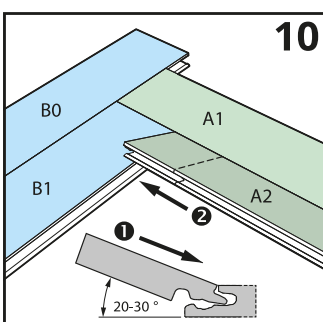

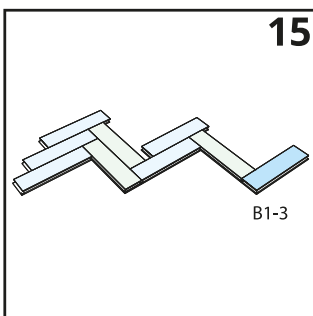
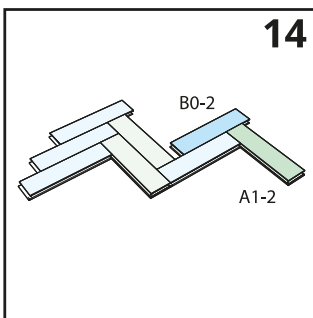
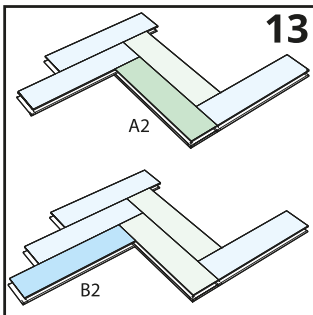
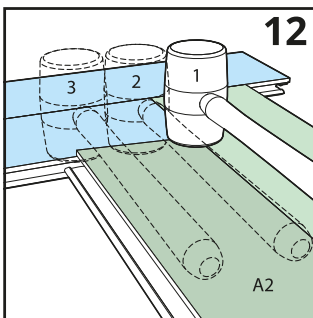
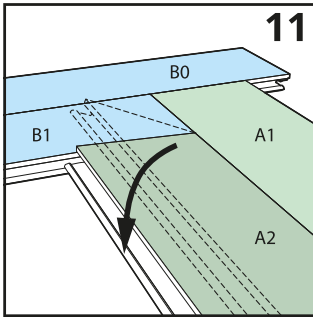

figure 13.

Tip: It is advisable to sit with your knees or stand with your feet on the already installed panels, to ensure that they don't start shifting during further installation.

Step 8. Follow the above steps 4 – 7 to continue the installation.

1. First you lay a (B0) panel as a temporary supporting panel.
2. Then you can connect the next (A) panel with the supporting (B0-2) panel and already installed (B) panel. The long side groove of panel (A1-2) can be joined with the short side tongue of the (B) panel by an angle movement. When the long side of panel (A1-2) is correctly installed, you can connect the tongue of the short side of panel (A1-2) with a fold-down movement into the groove of the long side of the supporting (B0-2) panel. Fully engage both the short side of the (B0-2) panel and the short side of panel (A1-2) by making use of the rubber hammer, in the same way as described above. See figure 14.

3. The next step is to connect the long side tongue of the next (B) panel to the short side groove of the newly installed (A) panel, by making use of an angle movement. See figure 15. Always ensure that the edges of the two panels are perfectly aligned with each other.

4. Now that you have created the next 'V-row', you can install the following 4 panels of this and the previous 'V-row'. Always connect the long side tongue of the panels to the long side groove of the adjacent panels by making use of an angle movement. Afterwards, connect the tongue on the short side

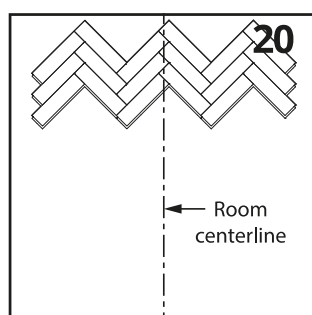
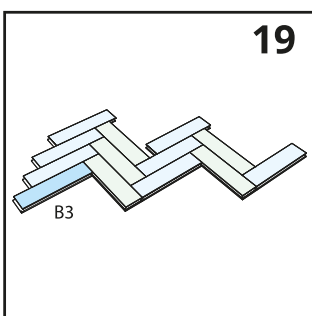
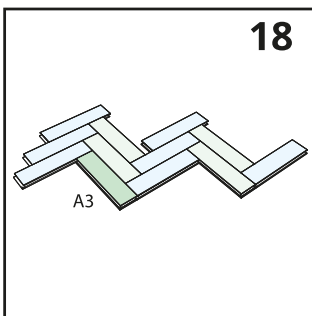
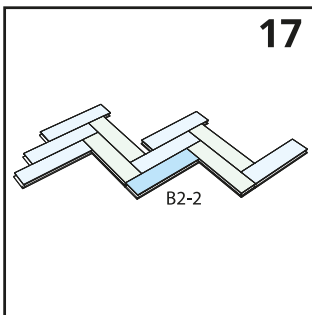
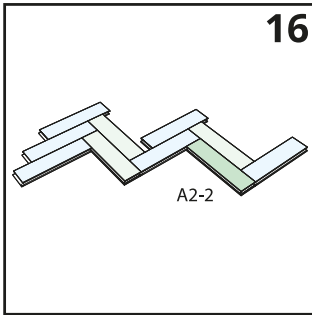

of the panels to the groove of the long side of the adjacent panels with a fold-down movement. See figures 16 - 19.

5. After installing these panels, you can start creating the next 'V-row' with a new supporting (B) panel and follow then repeat the above steps. It is very important to make sure the rows are perfectly centered in the middle of the room. Please take a moment to verify this.

Step 9. After having installed about 5 full V-rows, you can take away the supporting (B) panels and move the rows up to the starter wall, as shown in figure 20. Don't forget to take into account an expansion gap between the wall and the panels. Step 10. The open triangles between the starter wall and the installed V-rows still need to be installed.

These panels need to be cut off at the correct angle. To draw the cut-off line, rotate the panel by 180° and place it on the floor in its intended position, but with its corner aligned with the corner of the adjacent board, as indicated in figure 21 by the arrow and the letter "C". The dashed grey line in figure 21 shows that if the cut-off line was extended, it would intersect the corners of the nearby panels. The projecting grooves of the rotated panel will overlap the expansion gap while the cut-off is being marked. This expansion gap is needed to allow the floor to move naturally after installation. The marked panel can now be sawn. Insert the long sides of the cut-off panels at an angle of about 20-30 degrees. Press the panels down to ensure these long sides

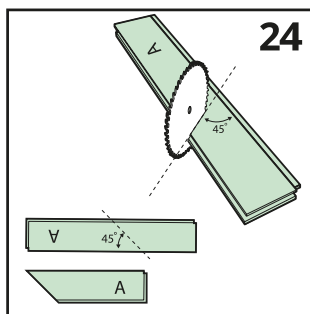
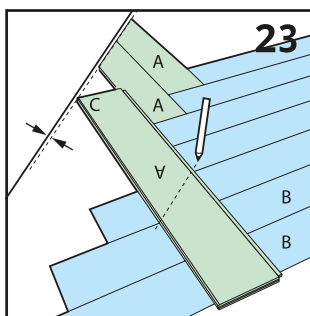
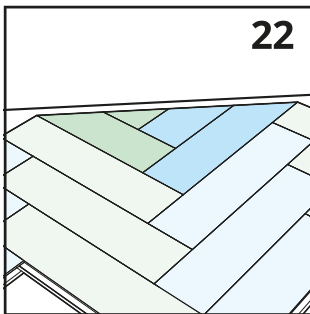
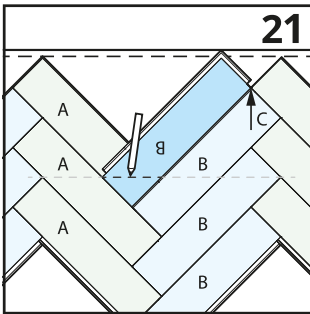

are fully connected. Finally connect the short sides of the panels by a snapping movement.

Use the tapping block and rubber hammer for this. Place the tapping block against the opposite short side of the panel and gently tap until the short sides of the panels are fully connected.

Tip: It is advisable to sit with your knees or stand with your feet on the already installed panels, to ensure that these panels don't start shifting during installation. Check after tapping panels into

place that they are still well connected and perfectly aligned.

Step 11. After installing all rows of full planks, the last step in the installation of the herringbone floor is the installation of the cut-off planks along the side walls of your room. To draw the cut-off line, rotate the panel by 180° and place it on the floor in its intended position. The corner "C" must be on the line of the expansion gap. Draw the line parallel with the wall, at the point where the rotated panel intersects the already installed panel (the position of the pencil in figure 23). Now you can saw the panels.

AREA FLOORS



Address: Ömerli Mah, Ilgaz Sok, No: 7/1, Arnavutköy / Istanbul

Phone: +90 (212) 741 51 61 E-Mail: info@areafloors.com.tr

New Generation Flooring

www.areafloors.com.tr

